

# Characterizing ammonia emissions from swine farms in eastern North Carolina: Reduction of emissions from water-holding structures at two candidate superior technologies for waste treatment

Viney P. Aneja<sup>a,\*</sup>, S. Pal Arya<sup>a</sup>, Ian C. Rumsey<sup>a</sup>, D-S. Kim<sup>a</sup>,  
K.S. Bajwa<sup>a</sup>, C.M. Williams<sup>b</sup>

<sup>a</sup>Department of Marine, Earth and Atmospheric Sciences, North Carolina State University, Raleigh, NC 27695-8208, USA

<sup>b</sup>Animal and Poultry Waste Management Center, North Carolina State University, Raleigh, NC 27695-7608, USA

Received 18 September 2006; received in revised form 11 July 2007; accepted 13 August 2007

---

## Abstract

Program OPEN (Odor, Pathogens, and Emissions of Nitrogen) was an integrated study of the emissions of ammonia (NH<sub>3</sub>), odor and odorants, and pathogens from potential environmentally superior technologies (ESTs) for swine facilities in eastern North Carolina. This paper, as part of program OPEN, focuses on quantifying emissions of NH<sub>3</sub> from water-holding structures at two of the best ESTs and compares them with the projected emissions from two conventional lagoon and spray technologies (LSTs). The evaluated ESTs are: (1) Super Soils at Goshen Ridge; and (2) Environmental Technologies at Red Hill. The water-holding structures for these two ESTs contained no conventional anaerobic lagoon. A dynamic flow-through chamber was used to measure NH<sub>3</sub> fluxes from the water-holding structures at both the ESTs and at the conventional LST farms. In order to compare the emissions from the water-holding structures at the ESTs with those from the lagoons at the conventional sites under similar conditions, a statistical-observational model for lagoon NH<sub>3</sub> emissions was used. A mass-balance approach was used to quantify the emissions. All emissions were normalized by nitrogen-excretion rates. The percentage reductions relative to the conventional lagoons were calculated for the two ESTs. Results showed substantial reductions in NH<sub>3</sub> emissions at both ESTs. Super Soils had reductions of 94.7% for the warm season and 99.0% for the cool season. Environmental Technologies had slightly larger reductions of 99.4% and 99.98% for the cool and warm season, respectively. As a result of such large reductions in ammonia emissions, both technologies meet the criteria to be classified as ESTs for ammonia emissions.

© 2007 Elsevier Ltd. All rights reserved.

*Keywords:* Ammonia emissions; Ammonia flux; Water-holding structures; Environmentally superior technologies (ESTs); Lagoon and spray technologies (LSTs)

---

## 1. Introduction

Atmospheric ammonia (NH<sub>3</sub>) is a very important alkaline constituent, and has a significant influence

---

\*Corresponding author. Tel.: +1 919 515 7808;  
fax: +1 919 515 7802.

E-mail address: [viney\\_aneja@ncsu.edu](mailto:viney_aneja@ncsu.edu) (V.P. Aneja).

on a variety of environmental processes (Aneja et al., 2006a, b). Ammonia reacts with a variety of acidic atmospheric species, such as sulfuric acid ( $\text{H}_2\text{SO}_4$ ), nitric acid ( $\text{HNO}_3$ ), and hydrochloric acid ( $\text{HCl}$ ), to form ammonium aerosols, namely, ammonium bisulfate ( $\text{NH}_4\text{HSO}_4$ ), ammonium sulfate ( $(\text{NH}_4)_2\text{SO}_4$ ), ammonium nitrate ( $\text{NH}_4\text{NO}_3$ ), and ammonium chloride ( $\text{NH}_4\text{Cl}$ ).

Ammonia and ammonium are removed from the atmosphere through both wet and dry deposition processes. Wet deposition occurs by either below cloud scavenging (washout) or by rainout (in-cloud processes). Atmospheric  $\text{NH}_3$  and its deposition lead to a variety of environmental consequences such as fine particulate matter formation, soil acidification and aquatic eutrophication.

Ammonia is emitted by a large variety of sources such as soils and agricultural crops, synthetic fertilizers, animal waste, biomass burning, fossil-fuel combustion, and human excreta (Oliver et al., 1996; Bouwman et al., 1997). Domestic animal waste is the leading source of global atmospheric ammonia. Studies suggest that it contributes between 20 and 35 Tg of nitrogen per year (Bouwman et al., 1997; Warneck, 2000). In North Carolina, swine waste is the dominant source accounting for 47% of all ammonia emissions, and it is estimated that about 75 000 tons of nitrogen per year are released by hog waste (Aneja et al., 1998). These emissions are related to a rapid increase in hog population, from approximately 3 million in 1992 to 10 million in 1997, when a moratorium was placed. The increase in hog population has been concentrated in the coastal plain region of North Carolina, which contains about 85% of the current pig population (Aneja et al., 2000). The lagoon and spray technology (LST) is the system currently employed to manage hog waste in North Carolina. It consists of an anaerobic lagoon to store and biologically treat the hog waste, which is then sprayed on nearby crops as a source of nutrients.

Due, in part, to the environmental problems associated with ammonia/ammonium emissions from LST farms, a moratorium in 1997 was placed on the construction of swine facilities and the expansion of existing swine facilities until September 2007.

In order to develop sustainable solutions to this problem, an agreement between the North Carolina Attorney General and several commercial hog farming companies was reached to develop poten-

tial environmentally superior technologies (ESTs) for hog facilities (Williams, 2001). Program OPEN (Odor, Pathogens, and Emissions of Nitrogen) was an integrated study of the emissions of ammonia, odor and odorants, and pathogens from potential ESTs for hog facilities. Its objectives were to evaluate 16 potential ESTs at swine facilities to determine if they would be able to substantially reduce atmospheric emissions of  $\text{NH}_3$ , pathogens, and odor from their observed or estimated emissions from the conventional LST used at selected conventional farms in different (warm and cool) seasons or observation periods. Previous papers present the results for the conventional LST farms (Aneja et al., 2007a), and the evaluation of six potential ESTs, that would need improvements/modifications to qualify as ESTs (Aneja et al., 2007b). This paper focuses on characterizing and quantifying emissions of  $\text{NH}_3$  from water-holding structures at two ESTs that met the specified performance standards (Williams, 2004) for ammonia emissions reduction, and therefore qualified as ESTs. This evaluation was achieved by comparing them with projected emissions from two conventional (also called, baseline) LST farms. The evaluated ESTs are: (1) Super Soils at Goshen Ridge; and, (2) Environmental Technologies at Red Hill. The water-holding structures for both of these ESTs contain no conventional anaerobic lagoon. Therefore, these might be considered to be most effective for reducing ammonia.

## 2. Methodology

### 2.1. Approach to evaluate ammonia emissions at EST farms

Ammonia flux measurements were conducted during 2-week periods representing different seasons (characterized here as warm and cool) at two EST sites in eastern North Carolina and also at two conventional farms (Stokes Farm and Moore Farm), which are also referred to as “baseline” sites for comparison with EST sites (for locations see Fig. 1). Measurements at the different sites were made at different times of the year. Therefore, to compare the EST and LST sites, the different environmental conditions at each site need to be taken into account. This is achieved by the development of a statistical-observational model (Aneja et al., 2007a).

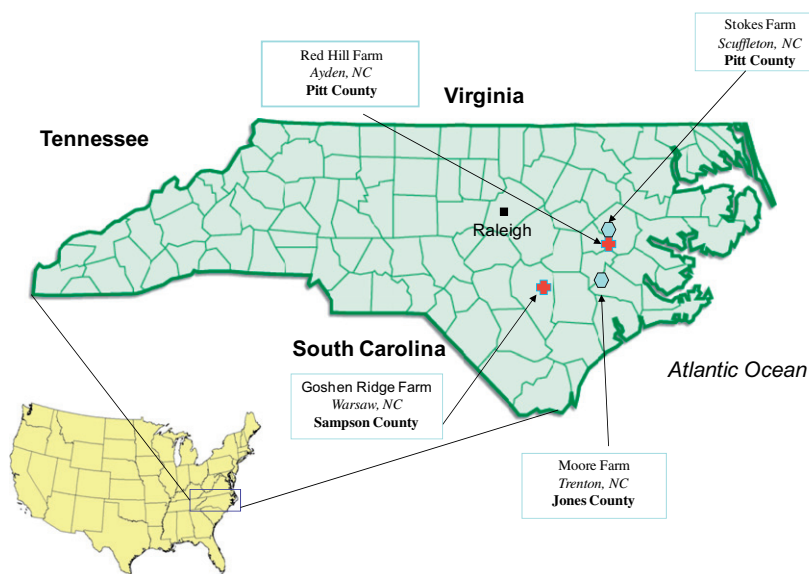

Fig. 1. Map of North Carolina indicating the location of the environmentally superior technologies (ESTs), and lagoon and spray technologies (LSTs). Blue hexagon indicates an LST farm, red cross an EST farm.

### 2.1.1. Statistical-observational model for lagoon $\text{NH}_3$ flux based on conventional farm measurements

Aneja et al. (2007a) developed a model based on flux measurement data from two conventional farms. For more information on the development of the model, the reader is referred to Aneja et al. (2007a). In this paper the model development is only briefly summarized.

The relationships between  $\text{NH}_3$  flux, lagoon temperature, pH and a range of environmental parameters were examined over a relatively wide range of lagoon temperatures ( $\sim 2\text{--}35^\circ\text{C}$ ) and lagoon–air temperature differences. These were observed during the warm and cool seasons at both conventional farms. The statistical–observational model was developed using multiple regression analysis on flux measurement data from two conventional farms. It is given as

$$\text{Log}_{10} F = 3.8655 + 0.04491(T_1) - 0.05946(D). \quad (1)$$

Here,  $F$  denotes the average  $\text{NH}_3\text{-N}$  emission from the conventional lagoon in  $\mu\text{g min}^{-1}(1000 \text{ kg lw})^{-1}$ ,  $T_1$  is the lagoon temperature in  $^\circ\text{C}$ , and  $D$  is a hot-air variable that is equal to zero if lagoon is warmer than air, but is equal to  $\Delta T = T_a - T_1$  when  $T_a > T_1$ , and  $T_a$  is air temperature in  $^\circ\text{C}$  at 2 m height. This statistical–observational model was used to estimate the projected  $\text{NH}_3\text{-N}$  flux from lagoons at the LST baseline farms to compare with the measured  $\text{NH}_3\text{-N}$  flux from water-holding structures at an EST site,

for the average values of  $T_1$  and  $D$  observed at the latter.

### 2.1.2. Estimation of % reduction in ammonia emissions at EST sites

Both the measured EST emissions and the model estimated LST emissions were normalized by the nitrogen excretion rate ( $E$ ) for the farm, and are called  $\%E$ , where  $\%E$  represents the loss of ammonia from a source, as a percentage of N-excretion rate. Nitrogen excretion was based on a mass balance approach. Nitrogen excretion rate ( $E$ ) in unit of  $\text{kg N week}^{-1} (1000 \text{ kg lw})^{-1}$  was determined using the following equation:

$$E = \frac{F_c \times N_f \times (1 - e_r)}{\bar{w}} \times 1000, \quad (2)$$

where  $F_c$  is the feed consumed ( $\text{kg pig}^{-1} \text{ week}^{-1}$ ),  $N_f$  is the fraction of nitrogen content in feed,  $e_r$  is the feed efficiency rate (ratio of average gain of nitrogen-to-nitrogen intake) (PigCHAMP, 1999), and  $\bar{w}$  is the average live animal weight ( $\text{kg pig}^{-1}$ ). Nitrogen excretion at each farm was calculated in term of the same units as  $\text{NH}_3\text{-N}$  emissions estimated from the water-holding structure of the EST farm and are shown in Table 1.

A potential EST was evaluated by comparison of  $\%E$  value from the EST ( $\%E_{\text{EST}}$ ) farm to  $\%E$  value from a baseline conventional farm ( $\%E_{\text{CONV}}$ ), and percent reduction of  $\text{NH}_3\text{-N}$  can

Table 1  
The summary of production data at environmentally superior technologies (ESTs) farms

Farm information	No. of pigs	Average pig weight (kg pig <sup>-1</sup> )	Total pig weight (kg)	Feed consumed (kg pig <sup>-1</sup> week <sup>-1</sup> )	N-content in feed (%)	N-excretion (kgN week <sup>-1</sup> (1000 kg-lw) <sup>-1</sup> )
<i>Goshen Ridge</i>						
April 2003	3519	93.4	328 675	17.03	2.67	3.41
February–March 2004	3138	99.8	313 172	16.18	2.49	2.83
<i>Red Hill</i>						
March–April 2005	2390	69.0	164 910	15.88	3.17	5.09
July–August 2005	3113	66.5	207 015	15.88	2.81	4.69

be estimated as

$$\% \text{reduction} = \frac{(\%E_{\text{CONV}} - \%E_{\text{EST}})}{\%E_{\text{CONV}}} \times 100. \quad (3)$$

An algorithmic flow diagram is shown in Fig. 2, which summarizes the evaluation of NH<sub>3</sub> emissions from water-holding structures at EST farms.

## 2.2. Sampling sites

### 2.2.1. LST sites

Stokes Farm (35.43°N, 77.48°W, 17 m MSL) is located in Pitt County, North Carolina. Measurement campaigns were conducted during 9–20 September 2002 and 6–17 January 2003, respectively. Four naturally ventilated finishing barns housed 4392 animals with an average weight of 104 kg in the fall season and 3727 animals with an average weight of 88 kg in the winter season. The waste (urine and feces) from the hog houses was flushed periodically (4 times a day) with recycled lagoon water and discharged into a storage lagoon from a single effluent pipe. The storage and treatment lagoon was an anaerobic system with 15 170 m<sup>2</sup> of lagoon surface area.

Sampling at Moore Brothers Farm (35.14°N, 77.47°W, 13 m MSL) located near Kinston in Jones County, NC, was conducted during 30 September–11 October 2002 and 27 January–7 February 2003. The farm has eight fully slatted finishing houses (pit recharge) with tunnel ventilation system. The eight finishing barns housed 7611 animals with an average weight of 52 kg in the fall season and 5784 animals with an average weight of 67 kg in the winter season. Pit recharge houses are typically flushed once a week. Waste from all the hog barns was flushed out with recycled lagoon water and discharged into a storage and treatment lagoon

from eight effluent pipes, one for each hog barn. The lagoon was an anaerobic system with 17 150 m<sup>2</sup> of surface area.

### 2.2.2. EST sites

The two EST sites were Goshen Ridge Farm and Red Hill Farm. A brief description of each of the potential ESTs that have been evaluated is provided here. Williams (2006) provides comprehensive detailed information including site plans, design schematics, economics, and projected operational characteristics associated with the technology.

*2.2.2.1. Goshen Ridge Farm (solids separation/nitrification–denitrification/soluble phosphorus removal/solids processing system (Super Soils)).* Goshen Ridge Farm is located near Beautancus, NC in Duplin County. The NH<sub>3</sub> measurements were conducted during 21 April–2 May 2003 for the warm season and 23 February–1 March 2004 for the cool season. A schematic layout of the EST at Goshen Ridge Farm, including the various sampling points, is given in Fig. 3.

The treatment system employed at Goshen Ridge Farm, known as Super Soils, treats the liquid portion of the waste. The liquid treatment begins with separation of the solid and liquid portions of the waste stream. Solids separation is accomplished using polyacrylamide, a flocculating agent.

The liquid portion of the waste stream flows between tanks in a circulating loop undergoing denitrification as a result of anaerobic activity in one tank, and nitrification through the use of concentrated nitrifying bacteria in the second tank under aerobic conditions. Nitrogen is removed from the waste stream during this stage of the process. The liquid then flows to a settling tank, where phosphorus is removed through the addition of

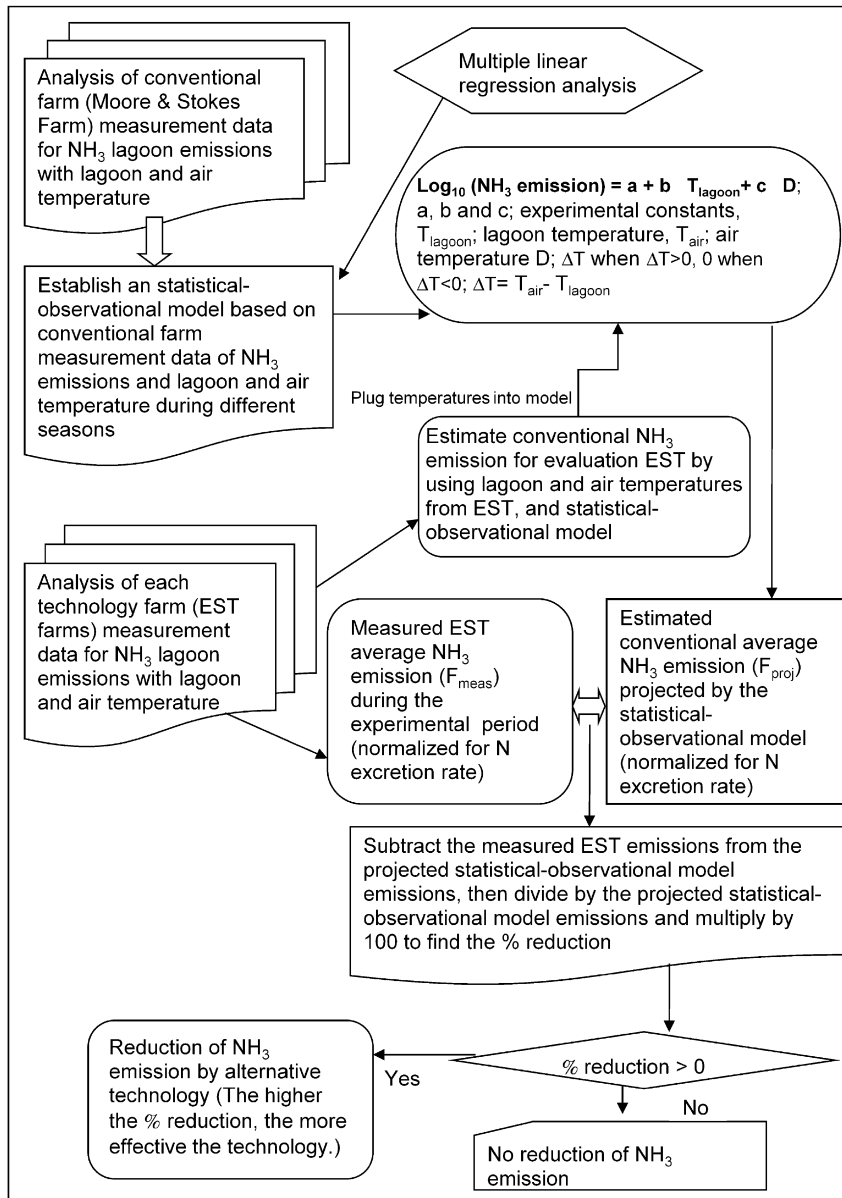

Fig. 2. Algorithm flow chart for evaluation of EST ammonia emissions from water-holding structures.

calcium hydroxide and a dewatering bag system. Calcium phosphate, which has value as a fertilizer, precipitates out during this process, providing a value-added product. During phosphorus removal, the pH of the liquid is raised to 10.5 using lime, which precipitates the soluble P and disinfects the effluent. Roughly 80% of the liquid is recycled through the hog houses, while 20% is used to irrigate crop fields.

At Goshen Ridge Farm, six naturally ventilated houses were treated by the potential EST. For the

warm season evaluation period there were 3519 pigs with an average weight of 93.4kg. For the cool season evaluations, there were 3138 pigs with an average weight of 99.8 kg for the February to March sampling period. For the warm evaluation period, NH<sub>3</sub> fluxes and emissions were measured from the homogenization tank, the 1st denitrification tank, the nitrification tank, the 2nd denitrification tank, and the storage tank. For the cool period evaluation, measurements were repeated in all the water-holding structures except the 2nd denitrification tank.

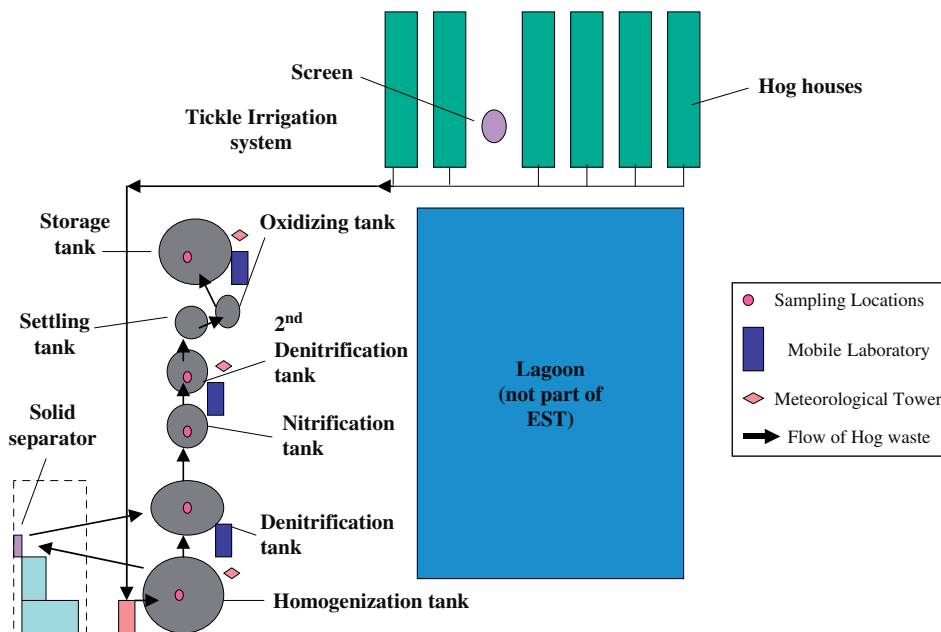

Fig. 3. A schematic layout of the potential EST at Goshen Ridge farm.

2.2.2.2. *Red Hill Farm ('closed loop' swine waste treatment system)*. Red Hill Farm is located near Ayden, NC, in Pitt County. Field campaigns were conducted from 21 March–8 April 2005 for the cool season, and 18 July–5 August 2005 for the warm season. A schematic layout of the EST at Red Hill Farm is given in Fig. 4.

The EST at Red Hill farm was provided by 'Environmental Technologies'. This EST is described as a "closed-loop" system, and its primary objective is to treat the liquid fraction of the waste in such a way that it can be used both for flushing the hog barns and for hog drinking water. This could eliminate the need for the traditional hog waste lagoon. A flush system is used for removing the manure from the barns, which, prior to installation of the treatment system, flushed the waste into a lagoon. The first step in the closed loop process is collection of the waste in an "equalization" or buffering tank. The waste in the tank is continuously pumped to an inclined separator, where the solids are collected and further treated. The liquid collected from the separator is injected with a polymer flocculant and sanitizer/disinfectant and pumped into a settling tank, where flocculated solids collect at the bottom over a period of approximately four hours.

Most of the liquid fraction from the settling tank is returned to the hog barns for re-use as flush

water. When the flush tanks are full, however, excess water is pumped to a tertiary treatment system. This system provides filtration and aeration and is housed in a septic tank. The treated water is blended with well water to achieve a dissolved-solids content that is consistent with human drinking water standards for use as hog drinking water. Solids from the settling tanks are combined with the solids from the inclined separator for further treatment.

At this EST farm there are three naturally ventilated hog houses in total. During the cool season evaluation period there were 2390 pigs with an average weight of 69.0 kg. For the warm season evaluation there were 3113 pigs with an average weight of 66.5 kg. During both experimental periods, measurements were conducted at the water tank and at both settling tanks.

### 2.3. Sampling technique and instrumentation

A dynamic flow-through chamber system was used to measure ammonia fluxes from water-holding structures at the potential ESTs and conventional farms. Various environmental measurements were also made simultaneously. Aneja et al. (2007a) gives a detailed description of the sampling techniques/scheme as well as the



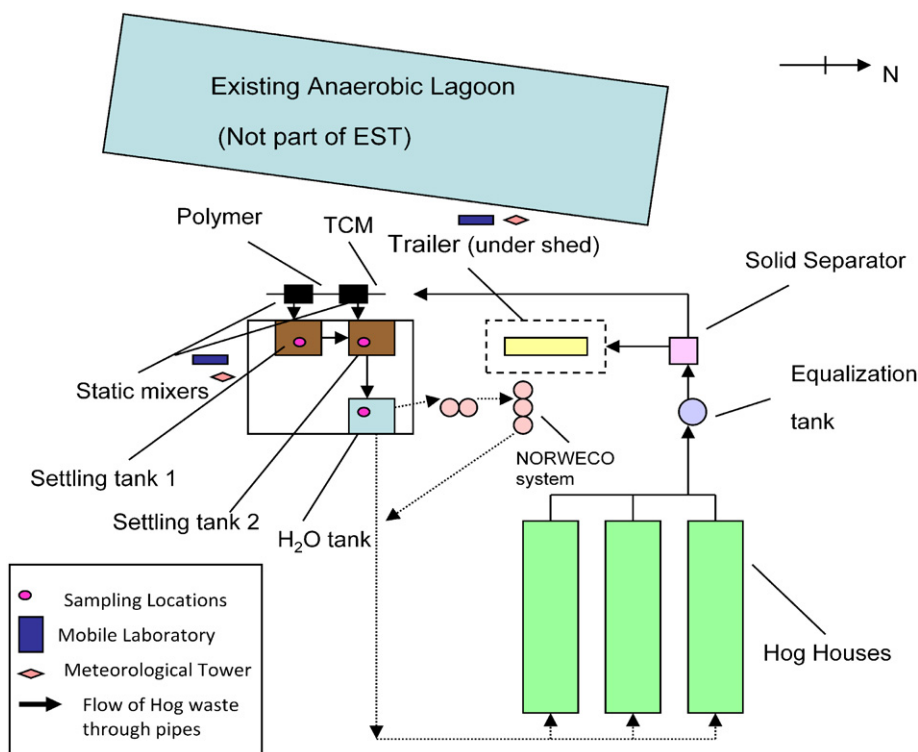

Fig. 4. A schematic layout of the potential EST at Red Hill farm.

instrumentation and environmental measurements used at each experimental site.

### 3. Results and discussion

#### 3.1. $\text{NH}_3$ fluxes and emissions from water-holding structures

Water-holding structure emissions from two EST farms (Goshen Ridge and Red Hill) were calculated from measurements of  $\text{NH}_3$  flux from EST farms, water-holding structure surface areas, and farm production data (number of pigs, feed consumed, and average pig weight) during experimental periods representing both cool and warm seasons. Emissions at the EST farms were normalized to steady-state live animal weight (lw) in the units of  $\text{kg N week}^{-1} (1000 \text{ kg lw})^{-1}$ . Average fluxes and total estimated emissions for the water-holding structures are given in Table 2.

At Goshen Ridge farm, ammonia flux measurements for the 1st experimental period were conducted from the homogenization tank, the denitrification tank, the nitrification tank, the 2nd denitrification tank and the storage tank. Their

water-holding structure surface areas were 91.6, 67.9, 28.3, 28.3, and  $91.6 \text{ m}^2$ , respectively.

For the 2nd experimental period, measurements were conducted for all of the same water-holding structures, except the 2nd denitrification tank.

During the 1st sampling period, the highest flux was measured at the denitrification tank, with a 15 min average flux of  $5838.1 \mu\text{g NH}_3\text{-N m}^{-2} \text{ min}^{-1}$ , and a maximum hourly average flux of  $6242.1 \mu\text{g NH}_3\text{-N m}^{-2} \text{ min}^{-1}$ . It should be noted, though, that the concentrations in the flux chamber were beyond the upper limit of detection of the ammonia analyzer; therefore flux values from this tank are highly uncertain. The homogenization tank had the 2nd highest flux with an average 15 min flux of  $3092.3 \mu\text{g NH}_3\text{-N m}^{-2} \text{ min}^{-1}$ , with a maximum hourly flux of  $6885.6 \mu\text{g NH}_3\text{-N m}^{-2} \text{ min}^{-1}$ . Although the homogenization tank has the larger surface area, the higher flux from the 1st denitrification tank results in this tank having the larger emissions.

The other water-holding structures were found to have much lower fluxes and emissions relative to the denitrification and homogenization tanks. The nitrification tank, 2nd denitrification tank and the

Table 2  
Average fluxes and total estimated emissions for the water-holding structures

Farm name and sampling period	Water holding structure	Average 15 min flux ( $\mu\text{g NH}_3\text{-N m}^{-2}\text{ min}^{-1}$ )	Water holding structure surface area ( $\text{m}^2$ )	Weekly $\text{NH}_3$ emissions ( $\text{kg N week}^{-1}$ )	Total emissions from water holding structures ( $\text{kg N week}^{-1}$ )	Total emission/pig ( $\text{kg N pig}^{-1}\text{ week}^{-1}$ )	Total emission/1000 kg-lw $^{-1}$ ( $\text{kg N week}^{-1}$ (1000 kg-lw $^{-1}$ ) <sup>a</sup> )
<i>Goshen Ridge</i>							
April–May 2003	Homogenization tank	3092.3	91.6	2.86	7.11	0.002	0.02
	Denitrification tank	5838.1	67.9	4.01			
	Nitrification tank	213.7	28.3	0.06			
	2nd Denitrification tank	543.1	28.3	0.15			
	Storage tank	33.6	91.6	0.03			
<i>Goshen Ridge</i>							
February–March 2004	Homogenization tank	881.1	91.6	1.36	1.41	0.0004	0.004
	Denitrification tank	33.5	67.9	0.02			
	Nitrification tank	32.4	28.3	0.01			
	Storage tank	13.7	91.6	0.02			
<i>Red Hill</i>							
March–April 2005	Settling tank 1	2073.9	5.8	0.12	0.44	0.0002	0.003
	Settling tank 2	5492.8	5.8	0.32			
	Water tank	80.4	5.8	0.00			
<i>Red Hill</i>							
July–August 2005	Settling tank 1	996.9	5.8	0.06	0.13	0.00004	0.0006
	Settling tank 2	1223.3	5.8	0.07			
	Water tank	43.3	5.8	0.00			

<sup>a</sup>The pig weight used to estimate per pig emissions was based on average pig weight in Table 1.

storage tank had 15 min average fluxes of 213.7, 543.1, and 33.6  $\mu\text{g NH}_3\text{-N m}^{-2}\text{ min}^{-1}$ , respectively. Correspondingly, the emissions followed the same pattern as the fluxes.

For all of the water-holding structures, the flux and emissions were lower in the 2nd evaluation period. For this evaluation, the average 15 min flux for the homogenization tank was the highest at 881.1  $\mu\text{g NH}_3\text{-N m}^{-2}\text{ min}^{-1}$ , with a maximum hourly average flux of 2059.5  $\mu\text{g NH}_3\text{-N m}^{-2}\text{ min}^{-1}$ . The most significant decrease in flux and emissions was from the denitrification tank, with an average 15 min flux of 33.5  $\mu\text{g NH}_3\text{-N m}^{-2}\text{ min}^{-1}$ . The storage tank had the lowest average flux, 13.7  $\mu\text{g NH}_3\text{-N m}^{-2}\text{ min}^{-1}$ . The emissions though were higher

than the emissions for the nitrification tank due to the storage tanks' larger surface area.

At Red Hill Farm, fluxes were measured from three water-holding structures, the two settling tanks and the treated water storage tank all of which had an area of 5.8  $\text{m}^2$ . Average fluxes during the March–April sampling period for settling tanks 1 and 2 were 2073.9 and 5492.8  $\mu\text{g NH}_3\text{-N m}^{-2}\text{ min}^{-1}$ , respectively. The treated water storage tank had the lowest flux value, with a flux of 80.4  $\mu\text{g NH}_3\text{-N m}^{-2}\text{ min}^{-1}$ . For the July–August 2005 measurement period, the pattern of flux values was repeated. The fluxes were 996.9, 1223.3, and 43.3  $\mu\text{g NH}_3\text{-N m}^{-2}\text{ min}^{-1}$ , for settling tanks 1, 2, and treated water storage tank, respectively. The



Table 3  
Summary of total NH<sub>3</sub> emissions from the EST farms and % reduction during the experimental periods

EST farms	Sampling periods	Measured emission ( $F_{\text{meas}}$ ) (kg N week <sup>-1</sup> (1000 kg lw) <sup>-1</sup> )	% $E_{\text{EST}}$	EST avg. lagoon temp (°C)	EST avg. D (°C)	Conventional lagoon emission (model/projected) ( $F_{\text{proj}}$ ) (kg N week <sup>-1</sup> (1000 kg lw) <sup>-1</sup> )	% $E_{\text{CONV}}$	% reduction
Goshen Ridge	April–May 2003	0.02	0.6	17.2	0.7	0.40	11.3	94.7
	February–March 2004	0.004	0.1	14.2	0.3	0.31	9.7	99.0
Red Hill	March–April 2005	0.003	0.06	14.9	0.5	0.32	10.0	99.4
	July–August 2005	0.0006	0.01	31.6	0.0	1.95	54.9	99.98

emissions from individual water-holding structures follow the same pattern as the fluxes.

### 3.2. Evaluation of ammonia emissions from water-holding structures

In order to evaluate the percentage reduction of NH<sub>3</sub> emissions for the water-holding structures, measured or estimated EST emissions were compared with projected emissions at the conventional LST farms. The estimated emissions from the LST farms were adjusted to the environmental conditions, i.e. air and lagoon temperature, which have been determined to be statistically correlated with ammonia emissions. For Environmental Technologies, lagoon temperature measurements were made at a lagoon on the farm that was not part of the EST. At Super Soils, no measurements were made at a lagoon. Therefore, in order to make a fair and logical comparison, lagoon data was used from an earlier reported EST with similar air temperatures. For the 1st evaluation at Super Soils (April–May 2003), the Barham farm (April 2002) lagoon (waste water-holding pond component) temperatures were used (Aneja et al., 2007b). For the 2nd evaluation (February–March 2004) at Super Soils, Barham farm (November 2002) lagoon temperatures were used.

Table 3 shows the summary of the water-holding structure NH<sub>3</sub> emissions measured from EST farms, projected emissions from the water-holding structures at the conventional (LST) farms, and % reduction values for their evaluation of potential N reduction.

For both farms there is substantial reduction in NH<sub>3</sub> emissions from water-holding structures. The Super Soils technology employed at Goshen Ridge

farm had reductions of 94.7% and 99.0% for the warm and cool season, respectively. The Environmental Technologies closed loop system had slightly larger reductions, with a reduction of 99.4% in the cool season, and 99.98% in the warm season.

## 4. Conclusions

Two potential ESTs with no conventional anaerobic lagoon component were evaluated to determine if they would substantially reduce atmospheric emissions of ammonia at the hog facilities and meet the performance standards as compared with estimated or projected emissions from the conventional LST used at two selected hog farms in two different (warm and cool) measurement periods. Both farms showed substantial reductions in NH<sub>3</sub> emissions from their water-holding structures. The Environmental Technologies closed loop system had the largest reductions, with reduction of 99.4% and 99.98% for the cool and warm season, respectively. Super Soils technology had a reduction of 94.7% in the cool season, and 99.0% in the warm season. This study did not address the potential reductions in odor and pathogens that were evaluated by other scientists in the OPEN project (Williams, 2006).

Under the conditions reported herein these two potential ESTs meet the criteria established for ammonia emissions as described for ESTs (Williams, 2004).

## Acknowledgments

Financial support provided by the North Carolina State University Animal and Poultry Waste Management Center (APWMC) is greatly

appreciated. We sincerely acknowledge the help and support provided by Ms. Lynn Worley-Davis. We thank the technology PIs, farm owners, Cavanaugh & Associates, and Mr. Bundy Lane, C. Stokes, and P. Moore for their cooperation.

We also thank the various people who assisted in fieldwork including, Hilawe Semunegus, Wesley Stephens, and Srinath Krishan.

We acknowledge the discussions and gracious help provided by Dr. John Fountain, Dr. Richard Patty, Dr. Ray Fornes, and Dr. Johnny Wynne of North Carolina State University. We thank Mark Barnes, Guillermo Rameriz, and Rachael Huie. We also thank Mr. Hoke Kimball, Mr. Mark Yarka, and Mr. Wade Daniels all of NC Division of Air Quality for their support, and Dr. Bruce Gay, US EPA; and Dr. Joette Steger, for their review of Project OPEN. Financial support does not constitute an endorsement by the APWMC of the views expressed in the report, nor does mention of trade names of commercial or noncommercial products constitute endorsement or recommendation for use.

## References

- Aneja, V.P., Chauhan, J.P., Walker, J.T., 2000. Characterization of atmospheric ammonia emissions from swine waste storage and treatment lagoons. *Journal of Geophysical Research* 105, 11,535–11,545.
- Aneja, V.P., Murray, G., Southerland, J., 1998. Proceedings of the Workshop on Atmospheric Nitrogen Compounds: Emissions, Transport, Transformation, Deposition, and Assessment. North Carolina State University, Raleigh, NC, 299pp.
- Aneja, V.P., Schlesinger, W.H., Niyogi, D., Jennings, G., Gilliam, W., Knighton, R.E., Duke, C.S., Blunden, J., Krishnan, S., 2006a. Emerging national research needs for agricultural air quality, *Eos, transactions. American Geophysical Union* 87 (3), 25–29.
- Aneja, V.P., Schlesinger, W.H., Knighton, R., Jennings, G., Niyogi, D., Gilliam, W., Duke, C.S. (Eds.), 2006b. Proceedings of the Workshop on Agricultural Air Quality: State of the Science. North Carolina State University, Raleigh, NC pp. 27695–7603.
- Aneja, V.P., Arya, S.P., Kim, D.S., Rumsey, I.C., Dickey, D., Stefanski, L.A., Arkinson, H.L., Semunegus, H., Bajwa, K., Robarge, W.P., Williams, C.M., 2007a. Characterizing ammonia emissions from swine farms in eastern North Carolina-Part I. Conventional Lagoon and Spray Technology for Waste Treatment. *Journal of Air and Waste Management Association*, in press.
- Aneja, V.P., Arya, S.P., Kim, D.S., Rumsey, I.C., Dickey, D., Stefanski, L.A., Arkinson, H.L., Semunegus, H., Bajwa, K., Robarge, W.P., Williams, C.M., 2007b. Characterizing ammonia emissions from swine farms in eastern North Carolina-Part II. Potential Environmental Superior Technologies for Waste Treatment. *Journal of Air and Waste Management Association*, in press.
- Bouwman, A.F., D.S. Lee, D.S., Asman, W.A.H., Dentener, F.J., Van der Hoek, K.W., Oliver, J.G.J., 1997. A global high-resolution emission inventory for ammonia. *Global Biogeochemical Cycles* 11, 561–587.
- Oliver, J.G.J., Bouwman, A.F., Van der Maas, C.W.M., Berdowski, J.J.M., Veldt, C., Bloos, J.P.J., Visschedijk, A.J.H., Zandveld, P.Y.J., Haverlag, J.L., 1996. Description of EDGAR Version 2.0: A set of global emission inventories of greenhouse gases and ozone depleting substances for all anthropogenic and most natural sources on a per country basis and on  $1^\circ \times 1^\circ$  grid. RIVM Technical Report 771060 002; TNO-MEP Report R96/119. National Institute of Public Health and the Environment/Netherlands, Organization for Applied Scientific Research, Bilthoven.
- PigCHAMP, 1999. National Summary Reports. PigCHAMP Inc., Ames, IA.
- Warneck, P., 2000. *Chemistry of the Natural Atmosphere*, second ed. Academic Press Inc., New York, NY, pp. 484–485, 511–528.
- Williams, C.M., 2001. Technologies to address air quality issues impacting animal agriculture. *Water Science and Technology* 44 (9), 233–236.
- Williams, C.M., (compiled and edited), 2004. Development of Environmentally Superior Technologies: Phase 1 Report for Technology Determination per Agreements Between the Attorney General of North Carolina and Smithfield Foods, Premium Standard Farms, and Frontline Farmers. Published by NCSU College of Agriculture and Life Sciences. July 26, 2004. 941p.
- Williams, C.M., (compiled and edited), 2006. Development of Environmentally Superior Technologies: Phase 3 Report-Technology Determinations per Agreements between the Attorney General of North Carolina and SmithfieldFoods, Premium Standard Farms and Frontline Farmers. Published by NCSU-College of Agriculture and Life Sciences, March 8, 2006. 716p. Also available at <[http://www.cals.ncsu.edu/waste\\_mgt/](http://www.cals.ncsu.edu/waste_mgt/)>.